

8

7

6

5

4

3

DWG. NO. 850280-001 SH 1 REV A

1

NOTES: UNLESS OTHERWISE SPECIFIED

REVISIONS				
ZONE	REV	DESCRIPTION	DATE	APVD
	A	REVISED AND REDRAWN RELEASED DRAWING	06/17/06	

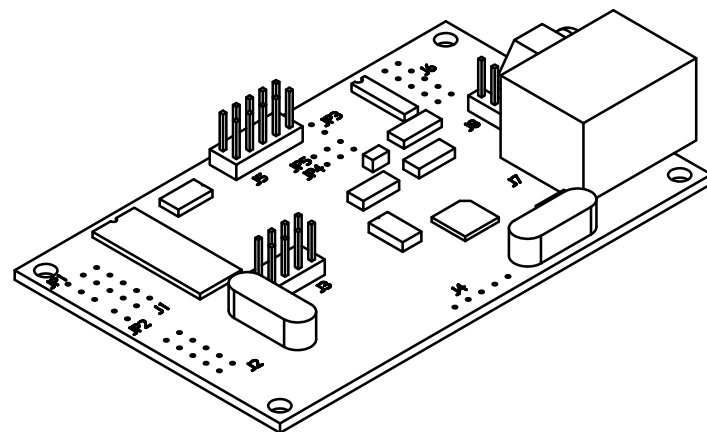
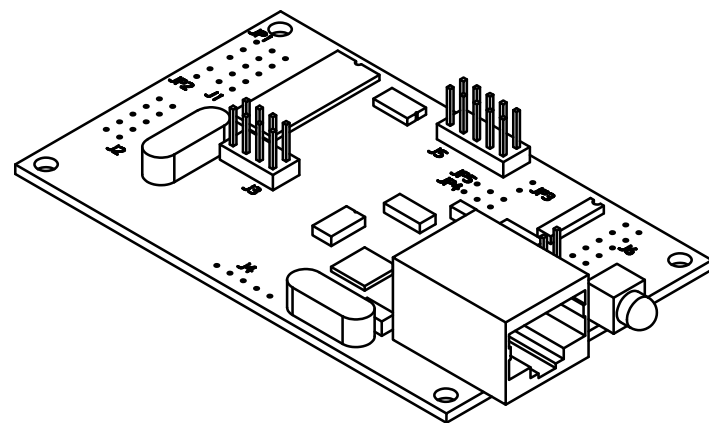
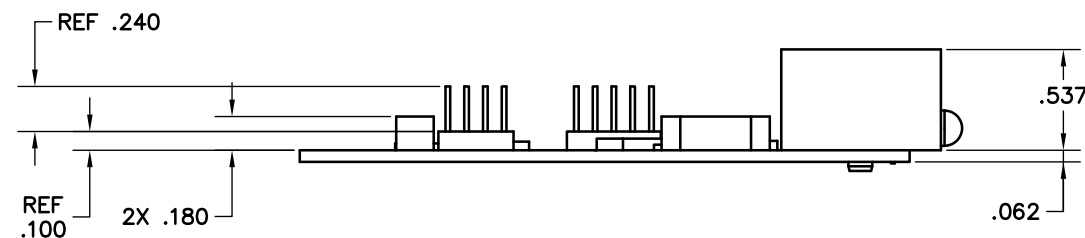
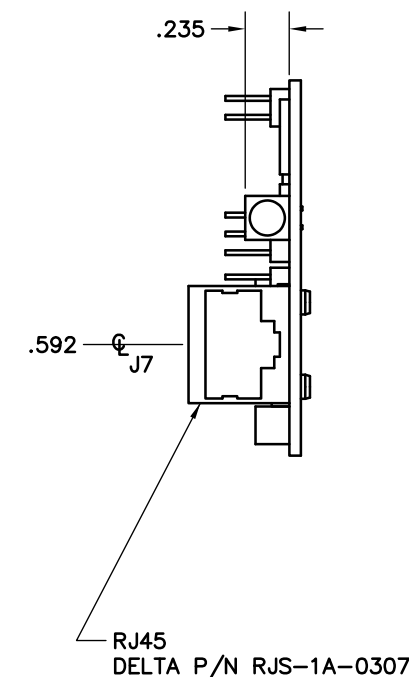
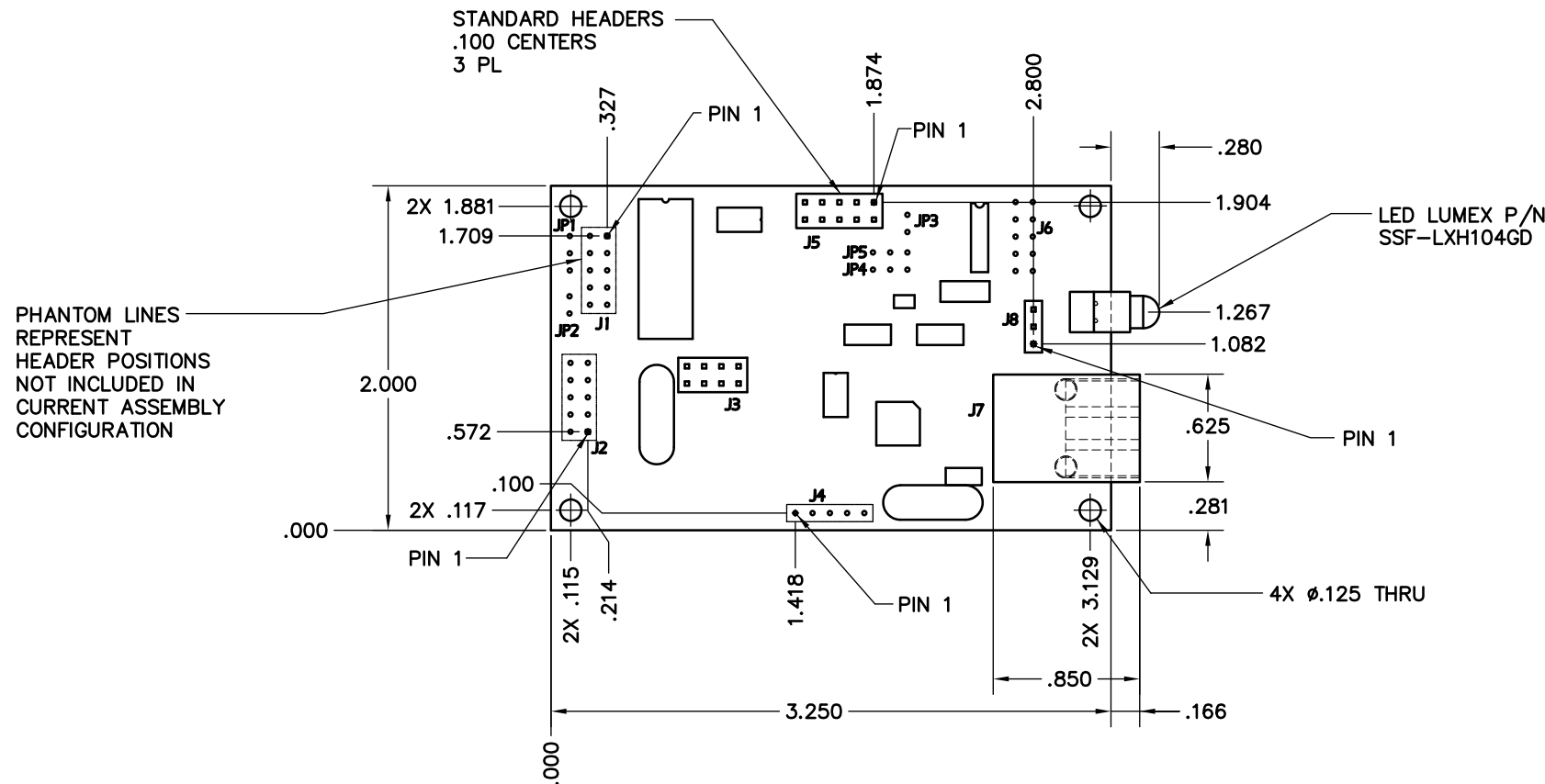

DO NOT SCALE DRAWING UNLESS OTHERWISE SPECIFIED DIMENSIONS ARE IN INCHES TOLERANCES: .x ± .1 .xx ± .02 .xxx ± .005 HOLE DIA UP TO .500 ± .002 HOLE DIA ABOVE .500 ± .013 ANGLES ± 0° 30' MACHINED SURFACES		PROPRIETARY INFORMATION NOT TO BE COPIED, USED, OR DISCLOSED WITHOUT WRITTEN PERMISSION FROM NETBURNER	5405 MOREHOUSE DR., STE 200 SAN DIEGO, CA. 92121 (858) 558-0293	
PROJECT MANAGER	PROJECT ENGINEER		OUTLINE DRAWING, SB70-100CR	
APPROVED	APPROVED	CAD/CAM DRAWING DO NOT MANUALLY REVISE OR UPDATE	SIZE	D
APPROVED	APPROVED		FSCM	
CHECKED BY	CHECKED BY	DRAWING NUMBER	850280-001	
APPLICATION	USED ON	SCALE	2/1	
		DATE	04/12/06	
		SHEET	1 OF 1	

5405 MOREHOUSE DR., STE 200
SAN DIEGO, CA. 92121
(858) 558-0293

**OUTLINE DRAWING,
SB70-100CR**

**CAD/CAM DRAWING
DO NOT MANUALLY
REVISE OR UPDATE**

SIZE	D	DRAWING NUMBER	850280-001	
SCALE	2/1		REV LTR	A
DATE	04/12/06		SHEET	1 OF 1

8

7

6

5

4

3

2

1