

---

## Adding an External Ethernet RJ-45 Connector and PCB Layout Guidelines for NetBurner -200 Version Modules

---

### Hardware Compatibility

- MOD5234-200IR
- MOD5270-200IR
- MOD5282-200IR
- SB70LC-200IR
- SBL2E-200IR

### Introduction

Specific NetBurner modules are available in two build configurations:

- With a RJ-45 Ethernet connector that has integrated magnetics and LEDs.
- With a 10-pin header that provides the Ethernet and LED signals from the PHY. This enables you to locate the RJ-45 elsewhere in your final product design, and also provides a lower height dimension for the module itself.

The purpose of this application note is to provide some design guidelines to assist you in adding an external Ethernet RJ-45 and magnetics to a NetBurner based design with the 10-pin header format.

### Hardware Design

Example design schematics are shown on following pages. No additional components are required if you are using one of the compatible RJ-45 Ethernet jacks with integrated magnetics and LEDs.

You may also use discrete magnetics if you prefer, as long as they are compatible with the Ethernet PHY on the module. **If you do decide to use alternate components, we strongly recommend contacting NetBurner Support for the latest revision information before you begin your design.**

# Compatible RJ-45 Jacks with Integrated Magnetics

Halo Electronics, P/N: HFJ11-E2450E-L11

Yuan Dean Scientific, P/N: 13F-641GGDP2NL

## PCB Layout Considerations

There are many considerations that can affect the layout of high frequency signals. The following are useful guidelines in most situations.

1. Avoid using cables or discrete wires, all signals should be routed on the PCB.
2. The trace distance between the module's 10-pin header and Ethernet magnetics should be kept as short as possible, and must be less than 3 inches.
3. A RJ-45 with integrated magnetics is preferred, but if using discrete magnetics the trace distance between the magnetics and the RJ-45 should be less than 1 inch.
4. The RX+/RX- and TX+/TX- signals should be routed in pairs and the traces of each differential pair should be of equal length. Separate the TX/RX differential pairs with a ground trace or plane, and route them far enough apart to avoid coupling. Otherwise an outgoing signal on the TX pair may create noise and false data in the RX pair.
5. Avoid any right angle trace bends, use at least a 45 degree angle or a curved trace. Do not vary the trace widths. Individual trace impedance should be kept below 50 ohms.

## Power Considerations

Noise from the power supply will show up on the Ethernet signals. The 3.3VDC power supplied to your NetBurner module should be within +/-5%.

## Design Notes

- Unlike most PHY transceiver designs the have a single signal pin providing link and activity status, the SBL2e PHY has link and activity on separate pins. The result is that on the SBL2e, one LED indicates 10/100 speed, and the other LED indicates link only, not activity.

# Example of a Core Module MODxxxx Design

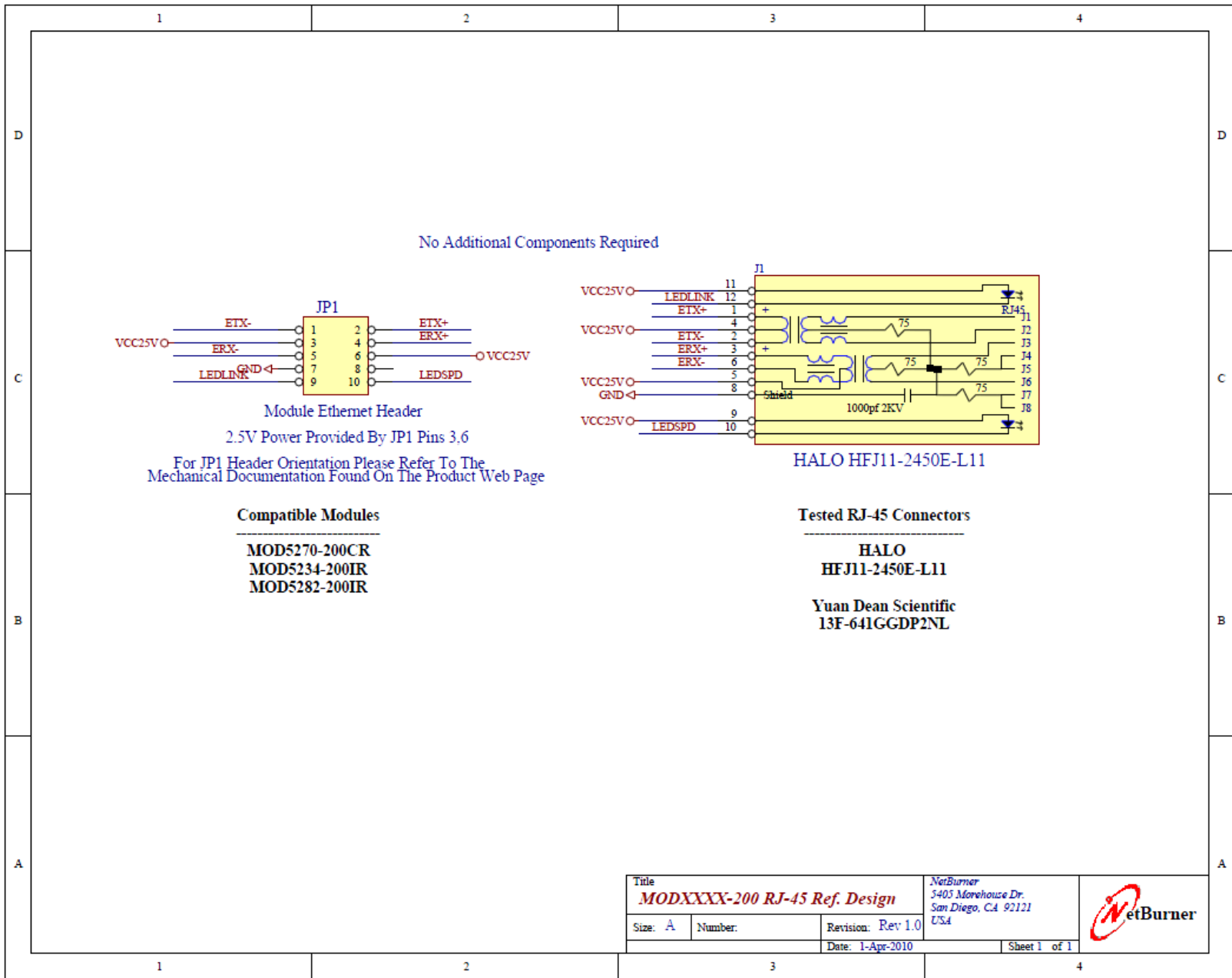

Title		NetBurner 5405 Morehouse Dr. San Diego, Ca 92121 USA	
<b>MODXXXX-200 RJ-45 Ref. Design</b>			
Size: A	Number:	Revision: Rev: 1.0	
		Date: 1-Apr-2010	Sheet 1 of 1



# Example of a SB70LC Design

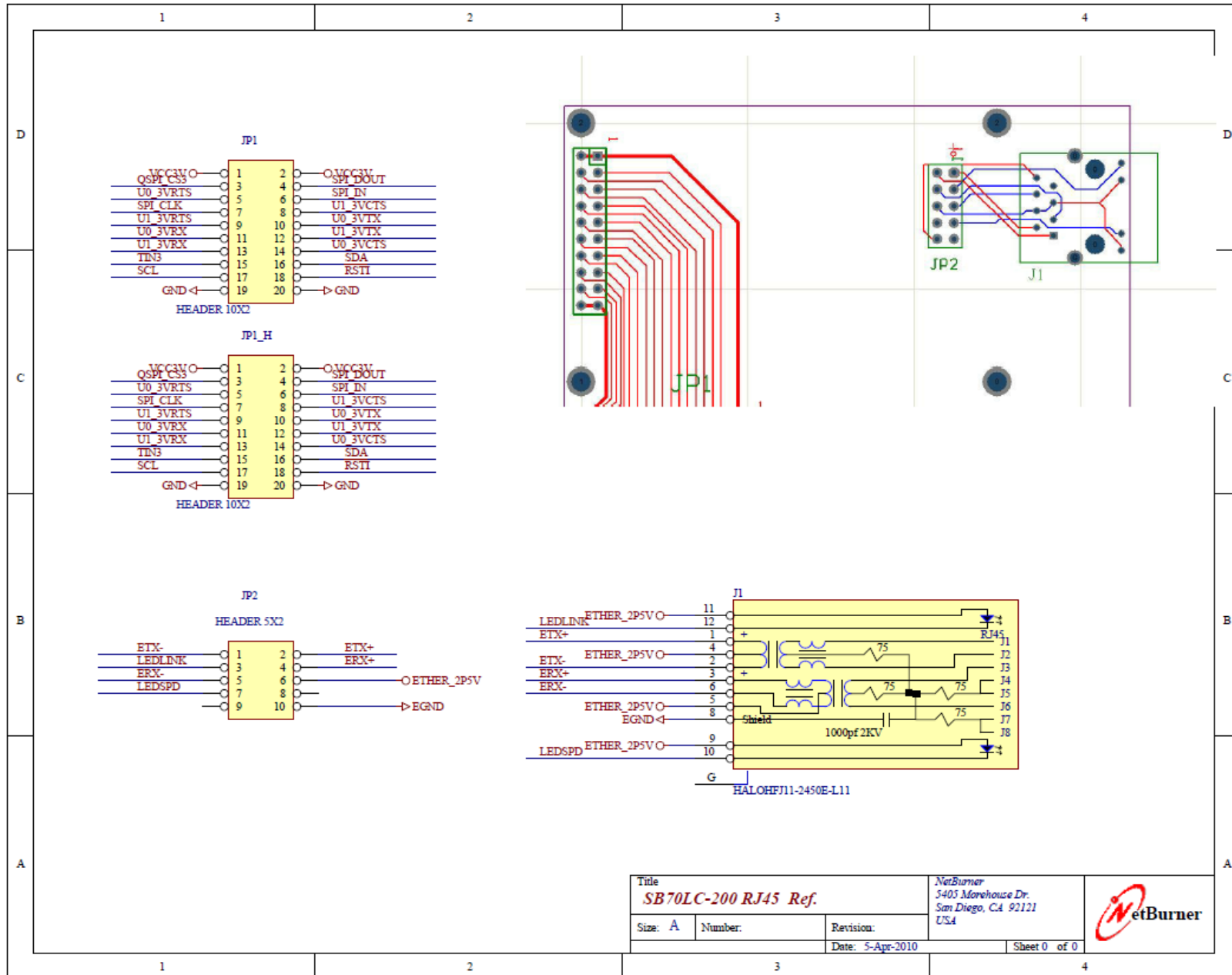

Title <b>SB70LC-200 RJ45 Ref.</b>		NetBurner 5405 Morehouse Dr. San Diego, CA 92121 USA	
Size: A	Number:	Revision:	
Date: 5-Apr-2010		Sheet 0 of 0	



# Example of a SBL2e Design

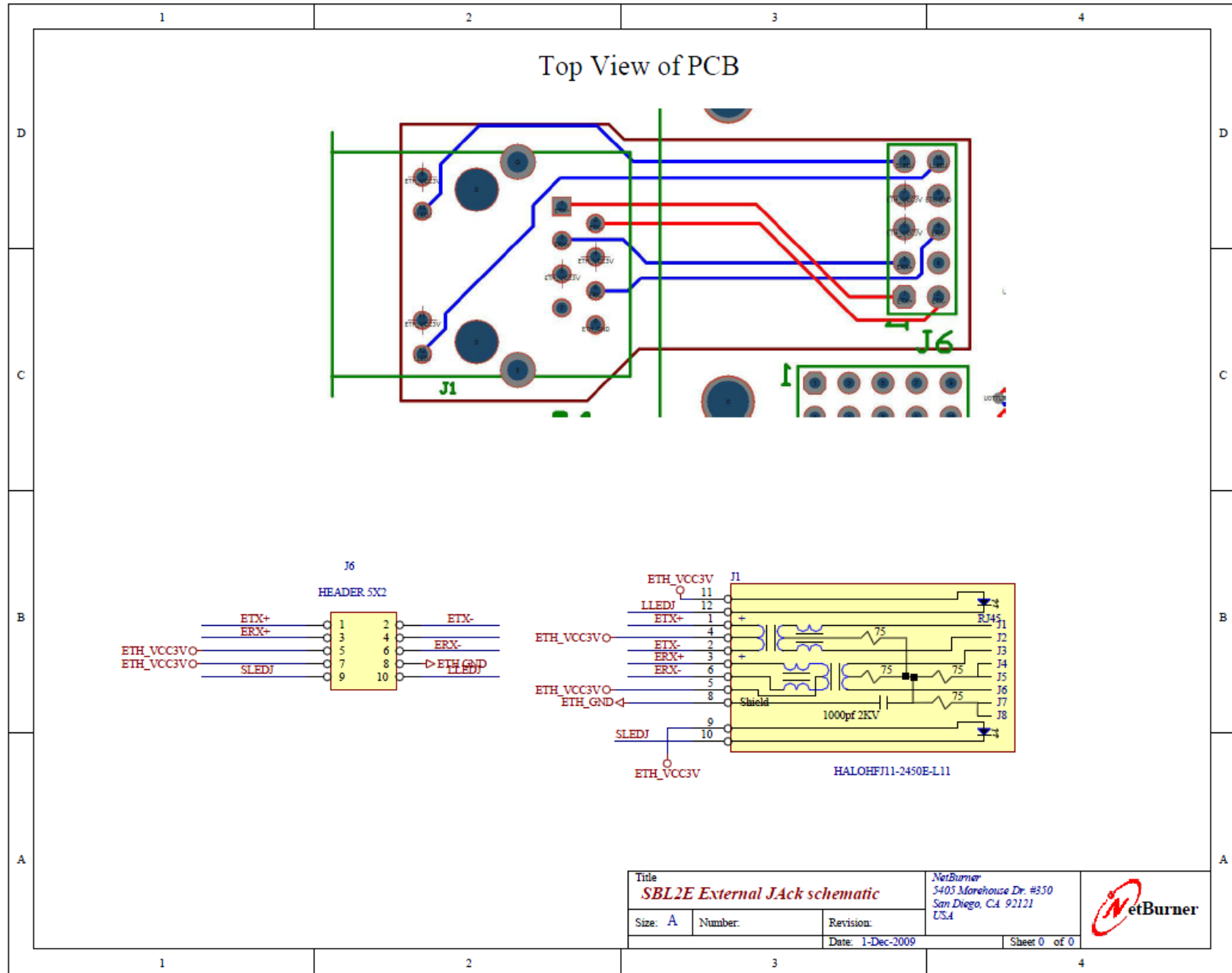

## Revision History

4/2/2010	1.0	Initial release
4/28/2010	1.1	Added Design Notes section